

Enhancing cooperation in MANET using the Backbone Group model (An application of Maximum Coverage Problem)

Arekatla Jaganmohan Reddy, Chevula Rekha, Butukuru Rojalakshmi, Vanapamula Veerabrahmachari

Associate Professor^{1,4}, Assistant Professor^{2,3}

jagan.arekatla@gmail.com¹, rekhavenkat16@gmail.com²,
brojalakshmi@gmail.com³, vveerabrahmachari@gmail.com⁴

Department of CSE, A.M. Reddy Memorial College of Engineering and Technology,
Petlurivaripalem, Narasaraopet, Andhra Pradesh

Abstract

Because each node in a MANET must perform routing and forwarding duties, the network as a whole has a higher energy and data need. The motivation for its non-cooperation is a sincere attempt to save energy and data transfer rates. By not include all nodes in routing operations, resource consumption may be decreased, which in turn improves cooperation. There are a number of efforts suggested in the literature that aim to achieve precise selection of nodes to establish a backbone. These works describe a backbone for MANET that is not possible due to unrealistic assumptions. In this study, we introduce the Backbone Group (BG) model, which uses a subset of the network's nodes for routing rather than all of them. A BG is an economically optimal subset of the network's nodes. We have sectioned off a MANET based on its one-hop neighbourhoods, which we've dubbed "locality groups." (LG). A LG consists of a cluster head (CH), regular nodes (RNs), and border nodes (BNs). (BNs). The CHs are the ones who make and oversee both LG and BG. By using a BG for a minimum amount of time before switching to another BG, the CHs ensure that all nodes in the network contribute to the network. Effectiveness in terms of routing overhead reduction is shown up to a ratio of $(n2: n2/k)$, where k is the number of LGs, using the suggested approach.

Keywords:

Cluster node; border node; regular node; backbone group; locality group.

Introduction

Due to the lack of fixed infrastructure and routers, a mobile ad hoc network (MANET) is a cooperative network. Due to the lack of routers, it is the responsibility of each node to perform critical functions like routing and forwarding. These nodes learn about one another to build a network, which is then used to route packets. If the desired node is too far away to reach directly, the network is flooded with broadcasts in an attempt to locate it. Self-organization, a dynamic topology, energy-constrained operation, multi-hop routing, etc., are only some of the distinguishing features that set it apart from a traditional infrastructure network. In order for an ad hoc network to "self-organize," all of its nodes must work together to perform tasks like addressing, routing, power management, etc. An ad hoc network's dynamic topology allows for a mobile node's unrestricted mobility while maintaining its connections to other mobile nodes and the network's ability to function cooperatively. A mobile node, in

particular, is one that may travel in any direction while still taking part in any given conversation. The energy restricted dilemma then explains how a mobile node must generally function with limited battery power and diminished compute performance to cut down on wasted energy. Battery life will decrease more quickly for mobile nodes that do sophisticated calculations or engage in extensive communication. In order to make advantage of the

low resource devices, a balancing mechanism must be designed. Since there was only so much radio signal to go around, the sender and receiver couldn't have a direct conversation. As a result, packets take a circuitous route to get where they're going. This requires cooperation amongst the intermediary nodes in the network.

Introduction, Review of Related Literature, and Rationale

A mobile ad hoc network (MANET) is a collection of wirelessly linked, self-managing nodes or routers. These nodes in the network operate independently and are responsible for forwarding and routing data. However, in order to save energy, nodes will delete packets from other sources, for both good and bad reasons (misbehavior¹). If a node is acting selfishly, it may discard a packet from another node in order to save energy or bandwidth. A malicious node uses wormhole and blackhole attacks to cause packet loss in the network. However, additional causes of packet loss include overloaded networks, interference, fading, and burst channel defects. Due to these causes, attacks involving data loss have become commonplace¹. These assaults prolong the time it takes for a packet to be delivered, increase its likelihood of being lost in transit, and reduce its efficiency.

Study of the Literature

The MANET is the most vulnerable to individualism. Several methods are discussed in the literature with the aim of reducing malicious routing activity. Cooperation in mobile ad hoc networks may be improved with the use of these methods, which employ detection and removal strategies. In this study, we focus on reducing the overall control traffic overhead as a means of discouraging selfish conduct. A plethora of incentive-based and reputation-based mechanisms^{1,2} is presented in the literature as ways to deal with routing misbehaviour. These safeguards prevent attacks and improper conduct in a network, but at the expense of more power and data transfer. In order to address the root cause of misbehaviour or non-cooperation—the drain on resources like battery life and network bandwidth—we suggest the BG model, in which only a subset of nodes (BG nodes) participate in routing operations.

Cooperation is bolstered by cost-cutting.

The energy restricted dilemma in wireless networks describes how a mobile node must make do with less processing power and shorter battery life in order to save energy. Battery life will decrease more quickly for mobile nodes that do sophisticated calculations or engage in extensive communication. As a result, improving collaboration necessitates cutting down on resource use¹. Many different strategies have been offered to reduce routing overhead and, by extension, the likelihood of malicious activity. T.

Chiang et al.³ suggested an Ad Hoc Network Partition Network Model. It employs mobile agents to reduce routing overhead using a partition network paradigm. Cooperation in ad hoc networks is improved as a result of the decreased burden of routing. For a routing with subnets scheme in MANETs⁴, J. López developed a new method of subnet formation and address allocation. The routing overhead is decreased with the suggested solution by using subnetting principles.

By segmenting a network into smaller, more manageable pieces, we can reduce the amount of spam in each area. As a result, it helps MANETs work together more efficiently and saves energy. Subnetting's weakness lies in the fact that it organizes nodes into subnets in the same way the internet does. The dynamic and scattered nature of MANET makes it challenging to use the subnetting idea. Challenges remain in areas including subnet construction and address acquisition, node mobility between subnets, and intra- and inter-subnet routing. In the literature, many effective models of virtual subnets were proposed^{5, 6, 7}. The decrease in routing overhead is a certain indicator that these approaches improve collaboration. However, devices with limited processing capabilities cannot make use of these methods. Because these methods need a great deal of computing power and authentication certificates. Akhtar and Sahoo suggested a unique method for securing an ad hoc network using the Friendly Group model⁸. Both border and regular nodes are used in this model. The border node utilizes its two NICs to divide the network into smaller, more manageable subnetworks. (FGs). Therefore, dividing a MANET into many FGs lessens the burden of controlling the whole network and improves collaboration.

An Overview of the Proposed Backbone Group Model

As an alternative to having every node take part in routing, we describe the Backbone Group (BG) concept here. At first, a MANET is conceptually broken down into the locality group (LG) seen in Fig. 2. There are three types of nodes in an LG: the cluster head (CH), regular nodes (RN), and border nodes. (BN). LGs, BGs, the option table, and the interchange of the option table between CHs, as well as the selection of a BG for network operations, are all the purview of the CHs. A BG is an economically optimal subset of the network's nodes. So that all nodes in the locality group share equally in the burden of routing, it is important that the BG utilized in network operations by the CHs be taken for a

threshold amount of time. Due to LGs being defined by one hop distance, our model makes no assumptions about reachability.

The BG Model's Various Stages

Both the Custer head selection and Locality Group construction stages, as well as the Backbone creation step, are included in our model.

Phase of Custer Head Selection and Formation of Locality Groups

Here, a collection of CHs is characterized in terms of high computing power and battery lifespan; for example, a captain's laptop^{16,17} might serve as a cluster node in a conflict zone due to its high computational power and long battery life. We haven't gone into how to choose a CH for the cluster here, but you may use any of the established methods^{18,19}. The cluster leaders then look at the nodes in their immediate vicinity to form locality groups based on the hop count between them.^(s). According to Fig. 1, the distance between two nodes is measured as the number of hops between their respective cluster head and regular node locations.

Let CH = (p1, p2) and RN = (q1, q2) then the Euclidean distance d is defin

$$d(CH, RN) = \sqrt{(p1 - q1)^2 + (p2 - q2)^2}$$

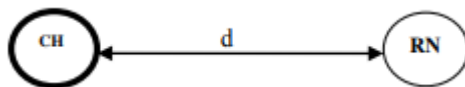

Fig. 1. Euclidean distance (d)

(d) If $d \leq r$ if the node is within r distance of the cluster head, it is considered to be part of that cluster's locality group. If an RN is located inside the service area of several CHs, those CHs will calculate their respective distances from the RN and divide up the surrounding area. CHs determine membership by weighing the proximity of an RN to another CH. A RN is chosen to join the LG based on the smallest distance between them. If all CHs are equally far from the RN, then the RN may be appended to any LG. Each locality cluster has a cluster head who is in charge of a group of regular nodes and one or more border nodes. The suggested locality group is shown in Fig. 2; it consists of a cluster head, a set of regular nodes, and one or more border nodes. Selecting a small subset of nodes that effectively

links the network together defines the backbone group. Border nodes are the typical vertices that make up a BG. The nodes in a locality group are shown in a grid layout in Fig. 2, although this arrangement is flexible depending on the need and the available communication channels. It also demonstrates that a cluster node of an LG is not limited to being located at the network's geographical hub. However, selecting a central node in a cluster allows for the covering of extensive physical distances.

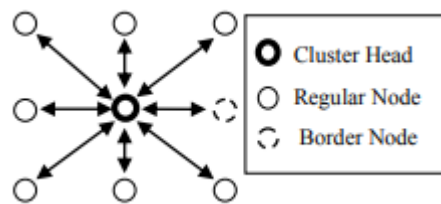

Fig. 2. Locality group

In a similar vein, multiple locale groups are formed on this basis, as seen in Fig. 3(a) and 3(b). Backbone nodes are represented by the circles with dashes, and their connections to other BGs are shown by the dotted lines. There are numerous other methods to organize a network into location groups; we've used these two examples.

A Review of the Experiments and Their Outcomes

We have utilized the Global Mobile Information System Simulator (GloMoSim)^{21,22,23} for our simulations. It's a flexible platform for simulating large-scale communication networks, both wired and wireless. Four GloMoSim^{21,22,23} files are utilized and configured to build up a scenario in accordance with the desired network. The CONFIG.IN file is where a scenario will be configured. The application layer protocols are configured via the APP.CONF file. To configure the mobility trace format, use the MOBILITY.IN file. The positioning of nodes is defined in the NODES.INPUT file. The simulation's settings are shown in Table 1.

Table 1. Simulation parameters.

Parameters	Values
SIMULATION-TIME	15M
TERRAIN-DIMENSIONS	(1250, 1250)
NUMBER-OF-NODES	121
NODE-PLACEMENT	GRID
MOBILITY	RANDOM-WAYPOINT
MOBILITY-WP-PAUSE	30S
MOBILITY-WP-MIN-SPEED	0
MOBILITY-WP-MAX-SPEED	10
MOBILITY-POSITION-GRANULARITY	0.5
PROMISCUOUS-MODE	YES
ROUTING-PROTOCOL	DSR

Table 2. Option Table.

BG_ID	BG_Nodes
BG ₁	c ₁ , (n ₅ , c ₁), (n ₄ , c ₂), c ₂ , (n ₇ , c ₂), (n ₂ , c ₄), c ₄ , (n ₄ , c ₄), (n ₅ , c ₃), c ₃ , (n ₂ , c ₃), (n ₇ , c ₁)
BG ₂	c ₁ , (n ₃ , c ₁), (n ₁ , c ₂), c ₂ , (n ₈ , c ₂), (n ₃ , c ₄), c ₄ , (n ₆ , c ₄), (n ₈ , c ₃), c ₃ , (n ₁ , c ₃), (n ₆ , c ₁)

In this work a BG is a minimal set of nodes that efficiently connects the network. To create a backbone, group a set of nodes are examined (as discussed in section 3.2.2) from each locality group which efficiently connect the network. A BG consists of a set of cluster nodes and border nodes that gives accurate connectivity of the network as shown in Fig. 4, in which a MANET is divided into four locality groups. The nodes of a backbone group are shown in Fig. 4 in which nodes of BG are {c₁, (n₅, c₁), (n₄, c₂), c₂, (n₇, c₂), (n₂, c₄), c₄, (n₄, c₄), (n₅, c₃), c₃, (n₂, c₃), (n₇, c₁)}.

Intergroup routing relies on the BG nodes, which link the network effectively. When another BG's intergroup routing period ends, the normal nodes engaged in the BG take over for a limited length of time and are referred to as border nodes. As indicated in Table 2, we have collected a number of BGs and placed them there so that all nodes may take part in network operations. These BGs may be constructed using any collection of nodes, for instance the network seen in Fig. 4.

$$BG_1 = \{c_1, (n_5, c_1), (n_4, c_2), c_2, (n_7, c_2), (n_2, c_4), c_4, (n_4, c_4), (n_5, c_3), c_3, (n_2, c_3), (n_7, c_1)\},$$

$$BG_2 = \{c_1, (n_3, c_1), (n_1, c_2), c_2, (n_8, c_2), (n_3, c_4), c_4, (n_6, c_4), (n_8, c_3), c_3, (n_1, c_3), (n_6, c_1)\} \text{ e}$$

A cluster head is denoted by its ID only while a regular node is denoted by an ordered pair (node_ID, CH_ID), where node_ID is node identity and CH_ID is cluster head identity.

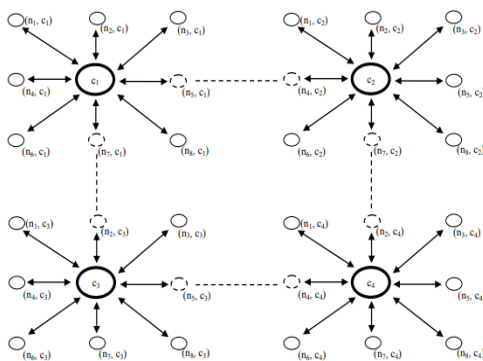

Fig. 4. Nodes of a backbone group

Results

In order to save energy, the suggested model segments networks into LGs. The BG model reduces the overall control traffic overhead by limiting the number of nodes involved in network activities. Our suggested approach decreased the control traffic overhead of reactive routing protocols²⁴ from n^2 to n^2/k , where k is the number of LGs. Figure 5 depicts the control traffic overhead with and without the BG model.

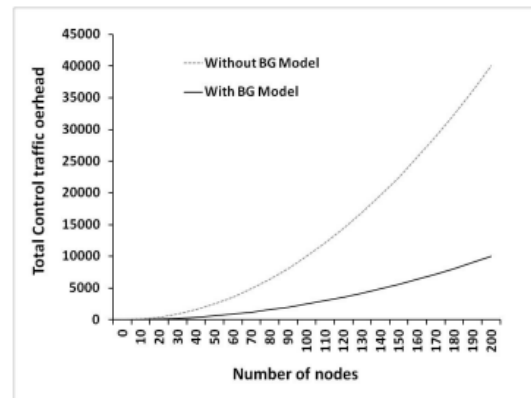

Fig. 5. Reduction in total control traffic overhead

Conclusion

Protecting a network against assaults and bad conduct using current technologies requires more bandwidth and battery life. Because of this, MANET was built on the premise that a secure system architecture should not only shield the network from assaults and malicious activity, but should also use as little resources as possible. In this research, we suggest the BG model to improve collaboration in MANET by enlisting just a subset of nodes (BG nodes) to carry out routing tasks. At first, the MANET is partitioned into location groups based on the number of hops between nodes. (LG). There are three types of nodes in an LG: the cluster head (CH), regular nodes (RN), and border nodes. (BN). LGs, BGs, the option table, and the interchange of the option table between CHs, as well as the selection of

a BG for network operations, are all the purview of the CHs. A BG is an economically optimal subset of the network's nodes. A collection of nodes from each locality group that effectively link the network is analysed to establish a backbone group. The model's early results indicate promise in reducing control traffic bottlenecks. By dividing the entire control traffic overhead for reactive routing protocols by the number of LGs, k , we were able to cut it in half. As a result, our methodology reduces overall control traffic overhead, which conserves resources while also addressing the root of the problem that leads to undesirable behaviour or lack of collaboration.

References

- [1]. Anusas-Amornkul T. *On detection mechanisms and their Performance for packet dropping Attack in ad hoc networks. ProQuest; 2008.*
- [2]. Wang Y. *Enhancing Node Cooperation in Mobile Wireless Ad Hoc Networks with Selfish Nodes. Doctoral Dissertation, Paper 602, University of Kentucky; 2008.*
- [3]. Chiang TC, Tsai HM, Huang YM. *A partition network model for ad hoc networks. In IEEE International Conference on Wireless and Mobile Computing, Networking and Communications 2005; 3: 467-472.*
- [4]. Lopez J, Barceló J M, García-Vidal J. *Subnet formation and address allocation approach for a routing with subnets scheme in MANETs. In Wireless Systems and Network Architectures in Next Generation Internet, Springer Berlin Heidelberg ; 2006. p. 62-77.*
- [5]. Chowdhury MAH, Ikram M, Kim KH. *Secure and survivable group communication over MANET using CRTDH based on a virtual subnet model. In Asia-Pacific Services Computing Conference IEEE APSCC'08; 2008.p. 638-643.*
- [6]. Chang CW, Yeh CH, Tsai CD. *An efficient authentication protocol for virtual subnets on mobile ad hoc networks. In International Symposium on Computer Communication Control and Automation (3CA) IEEE 2010;2:67-70.*
- [7]. Vilhekar AA, Jaidhar CD. *Modified Authentication Protocol Using Elliptic Curve Cryptosystem for Virtual Subnets on Mobile Adhoc Networks. In Wireless Communications and Applications Springer Berlin Heidelberg; 2012.p. 426-432.*
- [8]. Akhtar MAK, Sahoo G. *A Novel Methodology for Securing Ad Hoc Network by Friendly Group Model. In Computer Networks & Communications (NetCom), Springer 2013;131: 23-35.*
- [9]. Wu J, Dai F. *Virtual backbone construction in MANETs using adjustable transmission ranges. IEEE Transactions on Mobile Computing 2006; 5(9), 1188-1200.*
- [10]. El-Hajj W, Kountanis D, Al-Fuqaha A, Guizani S. *A fuzzy-based virtual backbone routing for large-scale MANETs. International Journal of Sensor Networks 2008; 4(4): 250-259.*
- [11]. Yang S, Wu J, Dai F. *Efficient directional network backbone construction in mobile ad hoc networks. IEEE Transactions on Parallel and Distributed Systems 2008;19(12): 1601-1613.*
- [12]. Ma Y, Jamalipour A. *Opportunistic Virtual Backbone Construction in Intermittently Connected Mobile Ad Hoc Networks. In Proceedings of the International Conference on Communications (ICC) IEEE;2011.p. 1-5.*
- [13]. Nemhauser GL, Wolsey LA, Fisher ML. *An analysis of approximations for maximizing submodular set functions—I. Mathematical Programming 1978; 14(1): 265-294.*
- [14]. Feige U. *A threshold of $\ln n$ for approximating set cover. Journal of the ACM (JACM) 1998; 45(4): 634-652.*
- [15]. Shamaiah M, Banerjee S, Vikalo H. *Greedy sensor selection: Leveraging submodularity. In Proceedings of the 49th IEEE Conference on Decision and Control (CDC);2010.p. 2572-2577.*
- [16]. Saeed NH, Abbod MF, Al-Raweshidy HS. *IMAN: An Intelligent MANET routing system. In Proceedings of the IEEE 17th International Conference on Telecommunications (ICT);2010.p. 401-404.*
- [17]. Saeed N. *Intelligent MANET optimisation system. Ph.D. Thesis, School of Engineering and Design, Electronic and Computer Engineering Department, Brunel University; 2011.*
- [18]. Singh AK, Sharma S. *Elite Leader Finding Algorithm for MANETs. In the 10th International Symposium on Parallel and Distributed Computing (ISPDC);2011.p.125-132.*
- [19]. Mohammed N. Otrok H, Wang L, Debbabi M, Bhattacharya P. *Mechanism Design-Based Secure Leader Election Model for Intrusion Detection in MANET. IEEE Transactions on Dependable and Secure Computing 2011;8(1): 89-103.*
- [20]. *Maximum Coverage Problem. http://en.wikipedia.org/wiki/Maximum_coverage_problem 21. Zeng X., Bagrodia R, Gerla M. GloMoSim: a library for parallel simulation of large-scale wireless networks, In Proceedings of the 12th Workshop on Parallel and Distributed Simulation (PADS 98)IEEE;1998.p.154-161.*